

Commodore

A 600

System Schematics

4/92

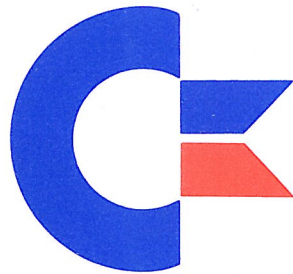

Commodore

Produced By:

**Commodore International Spare Parts GmbH
Braunschweig, West Germany**

SYSTEM SCHEMATICS

A600

APRIL, 1992

PN-400422-02

INTERNATIONAL EDITION

COMMODORE "INTERNATIONAL EDITION" SERVICE MANUALS CONTAIN PART NUMBER INFORMATION WHICH MAY VARY ACCORDING TO COUNTRY. SOME PARTS MAY NOT BE AVAILABLE IN ALL COUNTRIES.

Commodore Business Machines, Inc.

1200 Wilson Drive, West Chester, Pennsylvania 19380 U.S.A.

Commodore makes no express or implied warranties with regard to the information contained herein. The information is made available solely on an as is basis, and the entire risk as to completeness, reliability, and accuracy is with the user. Commodore shall not be liable for any damages in connection with the use of the information contained herein. The listing of any available replacement part herein does not constitute in any case a recommendation, warranty or guaranty as to quality or suitability of such replacement part. Reproduction or use without express permission, of editorial or pictorial content, in any matter is prohibited.

This manual contains copyrighted and proprietary information. No part of this publication may be reproduced, stored in a retrieval system, or transmitted in any form or by any means, electronic, mechanical, photocopying, recording or otherwise, without the prior written permission of Commodore Electronics Limited.

Copyright © 1992 by Commodore Electronics Limited.
All rights reserved. Printed in U.S.A.

TABLE OF CONTENTS

SECTION 1 — SPECIFICATIONS

SPECIFICATIONS 1-1

SECTION 4 — PARTS

BOARD LAYOUT 4-1

SHIPPING ASSEMBLY 4-2

MAIN ASSEMBLY 4-3

SHIPPING ASSEMBLIES 4-4

MAJOR ASSEMBLIES 4-5

PCB COMPONENTS 4-6

SECTION 5 — SCHEMATICS

SCHEMATIC #315987, REV. C 5-1

SECTION 1
SPECIFICATIONS

SPECIFICATIONS

INTRODUCTION

The A600 is a feature enhanced version of the A500 personal computer, in a smaller case with no numeric keypad.

FEATURES

CPU:	7.16MHz 68000 NTSC 7.09 MHz 68000 PAL
MEMORY:	512KB or 1MB internal expandable with additional 1MB external (A601)
KICKSTART ROM:	512K (V2.XX)
MASS STORAGE MEMORY:	Internal, 3.5 inch FDD mounted on the right side. The A600 HD will contain a 2.5" IDE HDD.
ADDITIONAL FEATURES:	PCMCIA/JEIDA Standard, Memory and I/O card interface. IDE Hard Drive Interface (2.5" form factor) Color Composite Video output RF Audio/Video Output

NEW ADDITIONS

- 1) 8375 FAT AGNUS which supports 2 Meg. of Chip RAM
- 2) 8373 ECS Denise
- 3) Full ECS support
- 4) V2.XX in ROM
- 5) Memory and I/O card interface
- 6) IDE Hard Drive Interface (2.5")
- 7) Color Composite Video Output
- 8) RF Video/Audio Output

CUSTOM CHIPS

The A600 custom chip set has been repackaged in PLCC form for surface mounting application. The A600 will use the 8375 2MB Fat Agnus, the 8373 ECS Denise and the 8364R7 Paula Chip which remains functionally unchanged. Lastly, the A600 will use an enhanced version of the 5719 Gary chip called Gayle, which supports the memory, I/O card interface and the IDE Hard Drive interface.

EXTERNAL SYSTEM I/O

External floppy, Serial, Parallel, Mouse, Joystick, Stereo Audio Ports — these Ports remain unchanged from their A500 counterparts.

PC CARD
PCMCIA SIGNAL DESCRIPTIONS

No.	Ver. 3	No.	Ver. 3
1	GND	35	GND
2	D3	36	CD1
3	D4	37	D11
4	D5	38	D12
5	D6	39	D13
6	D7	40	D14
7	CE1	41	D15
8	A10	42	CE2
9	OE	43	(RFSH)
10	A11	44	(OP1)
11	A9	45	(OP2)
12	A8	46	A17
13	A13	47	A18
14	A14	48	A19
15	WE/PGM	49	A20
16	(RDY/BSY)	50	A21
17	VCC	51	VCC
18	VPP1	52	VPP2
19	A16	53	A22
20	A15	54	A23
21	A12	55	RFU
22	A7	56	RFU
23	A6	57	RFU
24	A5	58	RFU
25	A4	59	RFU
26	A3	60	RFU
27	A2	61	(REG)
28	A1	62	OP3
29	A0	63	BVD1
30	D0	64	D8
31	D1	65	D9
32	D2	66	D10
33	WP	67	CD2
34	GND	68	GND

IDE SIGNAL DESCRIPTIONS

Pin	Signal	Pin	Signal
1	- Host reset	2	Ground
3	+ Host data 7	4	+ Host data 8
5	+ Host data 6	6	+ Host data 9
7	+ Host data 5	8	+ Host data 10
9	+ Host data 4	10	+ Host data 11
11	+ Host data 3	12	+ Host data 12
13	+ Host data 2	14	+ Host data 13
15	+ Host data 1	16	+ Host data 14
17	+ Host data 0	18	+ Host data 15
19	Ground	20	Key
21	Reserved	22	Ground
23	- Host Low	24	Ground
25	- Host IOR	26	Ground
27	Reserved	28	+ Host ALE
29	Reserved	30	Ground
31	+ Host IRQ 14	32	- Host ID 16
33	+ Host Addr 1	34	- Host PIAG
35	+ Host Addr 0	36	+ Host Addr 2
37	- Host CS 0	38	- Host CS 1
39	- Host SLV/ACT	40	Ground

SECTION 4

PARTS

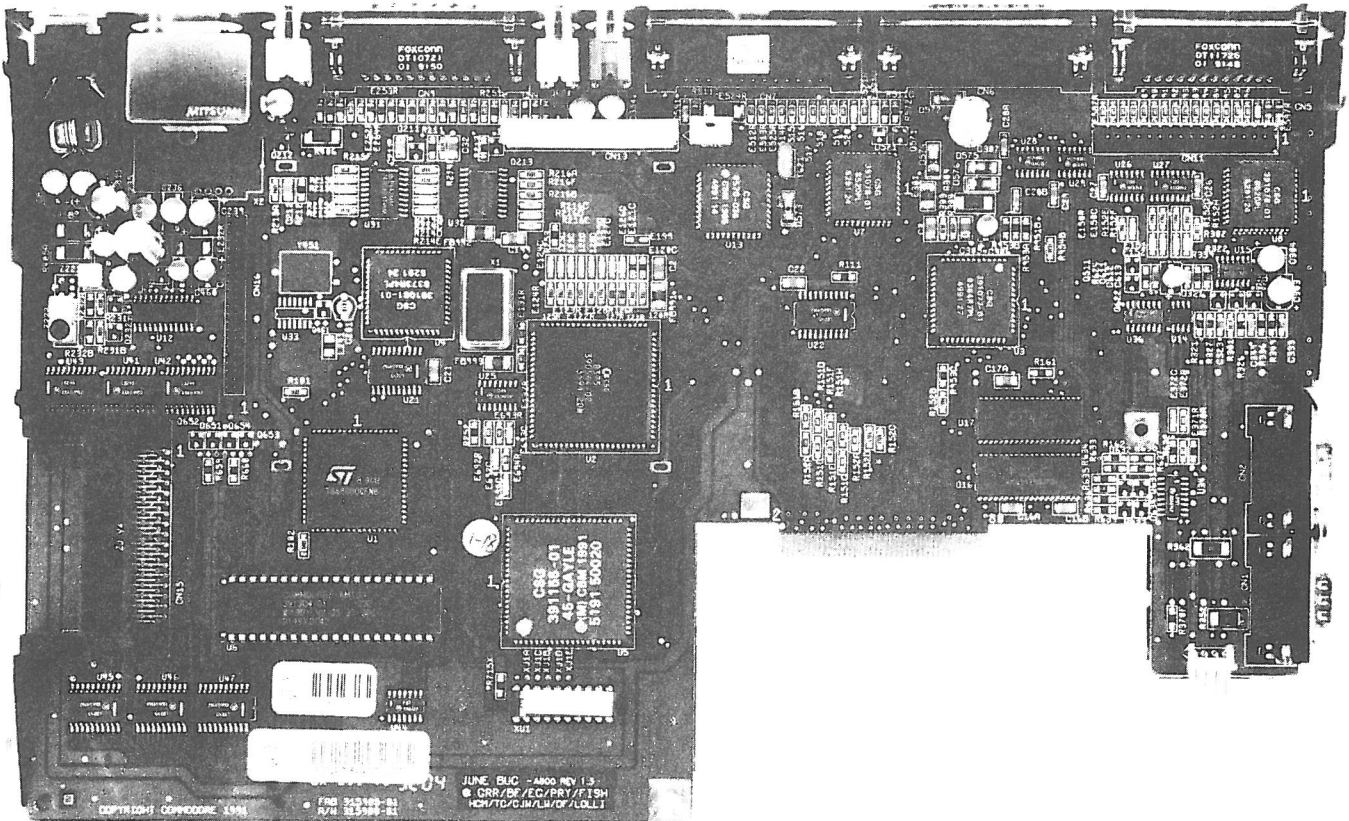

KEY COMPONENTS

Ref.	Chip	Description	Part Number
U1	68000	68000 Processor 8MHz	390084-01
U2	8375	ECS Agnus A300/A500 +	390544-01
U3	8364	Paula	391077-01
U4	8373	ECS Denise	391081-01
U5	4145-20	Gayle Gate Array	391155-01
U6	ASST	ROM 256Kx16, 200ns	391304-01
U7-8	8520	Amiga VIA. 1 MHz	391078-01
U10-11	28F10	Flash Memory 128Kx8	
U12	CXA1145	Sony Video Encoder	391084-01
U13	6570-30	Amiga Keyboard MPU	391079-01
U14	NE555	Reset Timer	391104-01
U16-17	ASST	Dram 256Kx16, 120ns	391105-01
U15	LF347	Bimos Op-Amp	391103-01
	TL084	Bimos Op-Amp	391103-01
U28	1488	EIA Line Driver	391087-01
U29	1489	EIA Line Receiver	391086-01
X1	OSC	TTL 28.63636 MHz NTSC	325566-14
	OSC	TTL 28.37512 MHz PAL	252344-01
Y451	XTAL	4.43619 MHz PAL Burst	252345-01
Y621	XTAL	3 MHz Ceramic Resonator	391156-01
X2	ASST	PAL Video Modulator	313371-05
	ASST	NTSC Video Modulator	313371-01

CONNECTORS

Ref.	Type	Description	Part Number
CN1	DB9P	Mouse/Joystick 1	390242-01
CN2	DB9P	Mouse/Joystick 2	390242-01
CN3	RCA-J	Right Audio Output	252122-02
CN4	RCA-J	Left Audio Output	252122-01
CN5	DB23S	External Floppy	390241-03
CN6	DB25P	RS232 Serial Port	
CN7	DB25S	Parallel Printer Port	390241-05
CN8	SQ DIN	Power Supply Connector	252167-01
CN9	DB23P	Video Output	390242-03
CN10	RCA-J	Composite Video	252122-01
CN11	DIL-34	Internal Floppy Signal	903345-17
CN12	SIL-4	Internal Floppy Power	325516-04
CN13	MEM-30	Keyboard Membrane	390492-02
CN14	SIL-4	Internal Floppy Power	
CN13	MEM-30	Keyboard Membrane	
CN14	SIL-4	Keyboard Status LED's	391314-01
CN15	PCMCIA	PC "Memory Card"	391073-01
P9	EDGE-80	Memory Bus Expansion	

Shipping Assembly

A600 SYSTEM SCHEMATICS

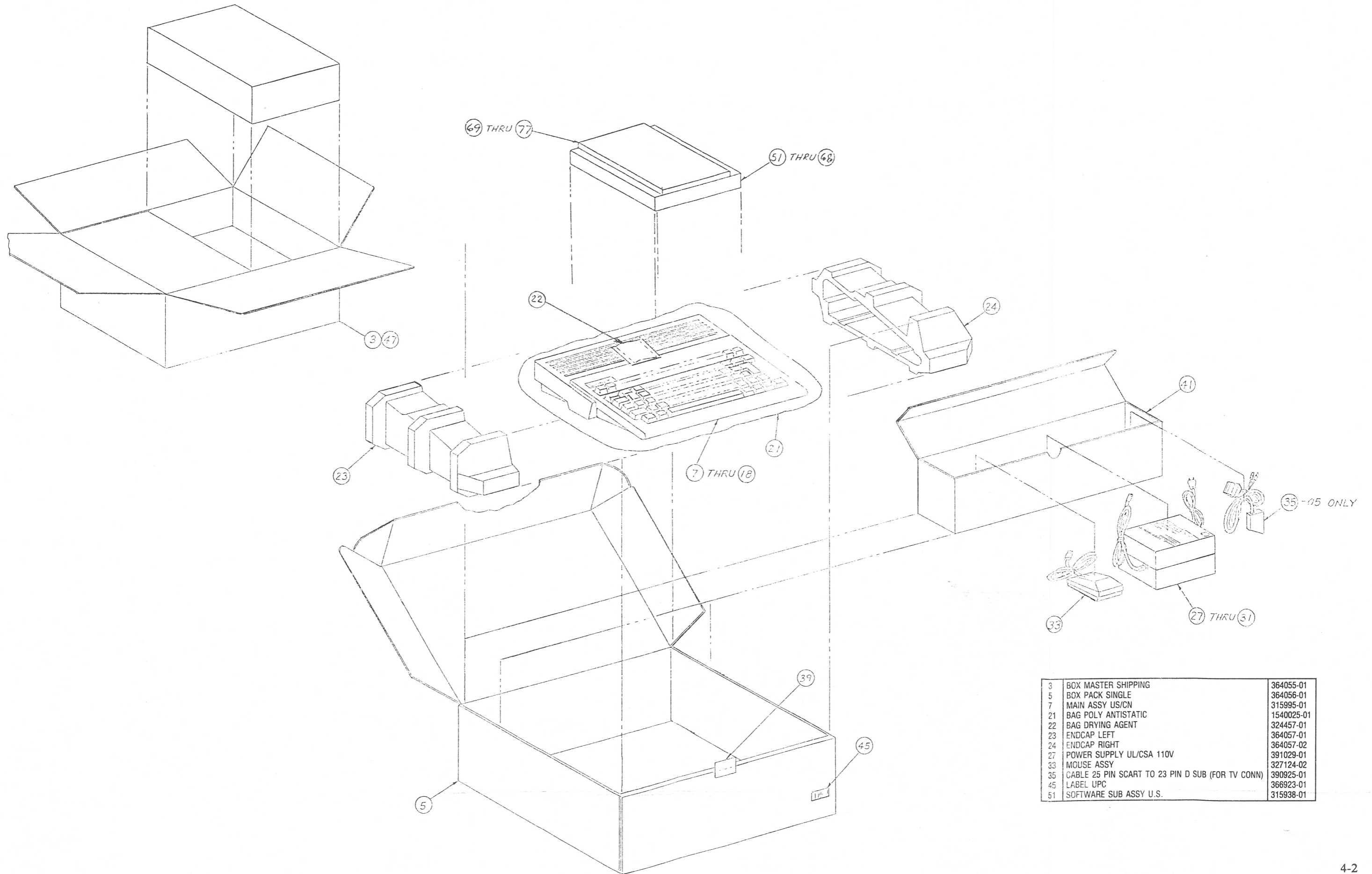

3	BOX MASTER SHIPPING	364055-01
5	BOX PACK SINGLE	364056-01
7	MAIN ASSY US/CN	315995-01
21	BAG POLY ANTISTATIC	1540025-01
22	BAG DRYING AGENT	324457-01
23	ENDCAP LEFT	364057-01
24	ENDCAP RIGHT	364057-02
27	POWER SUPPLY UL/CSA 110V	391029-01
33	MOUSE ASSY	327124-02
35	CABLE 25 PIN SCART TO 23 PIN D SUB (FOR TV CONN)	390925-01
45	LABEL UPC	366923-01
51	SOFTWARE SUB ASSY U.S.	315938-01

Main Assembly

A600 SYSTEM SCHEMATICS

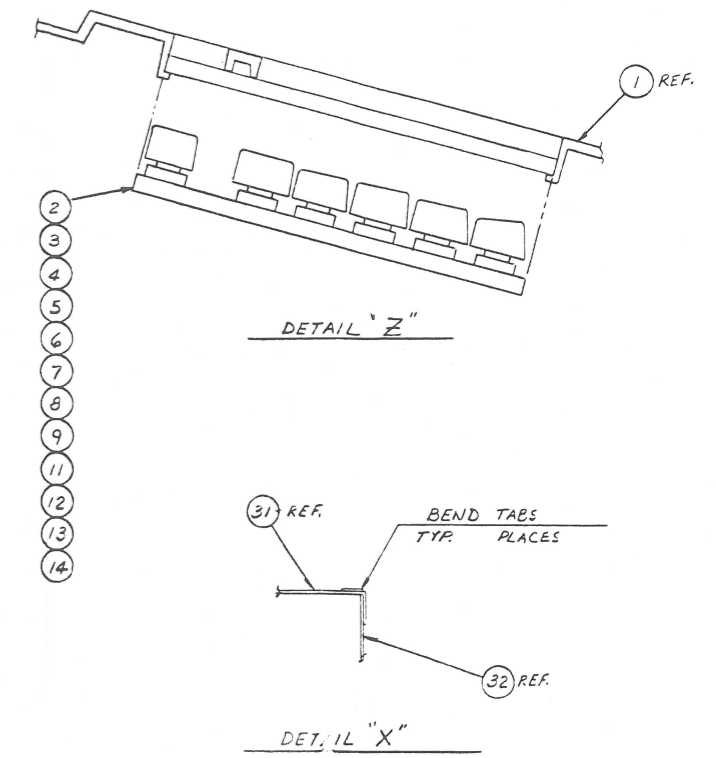
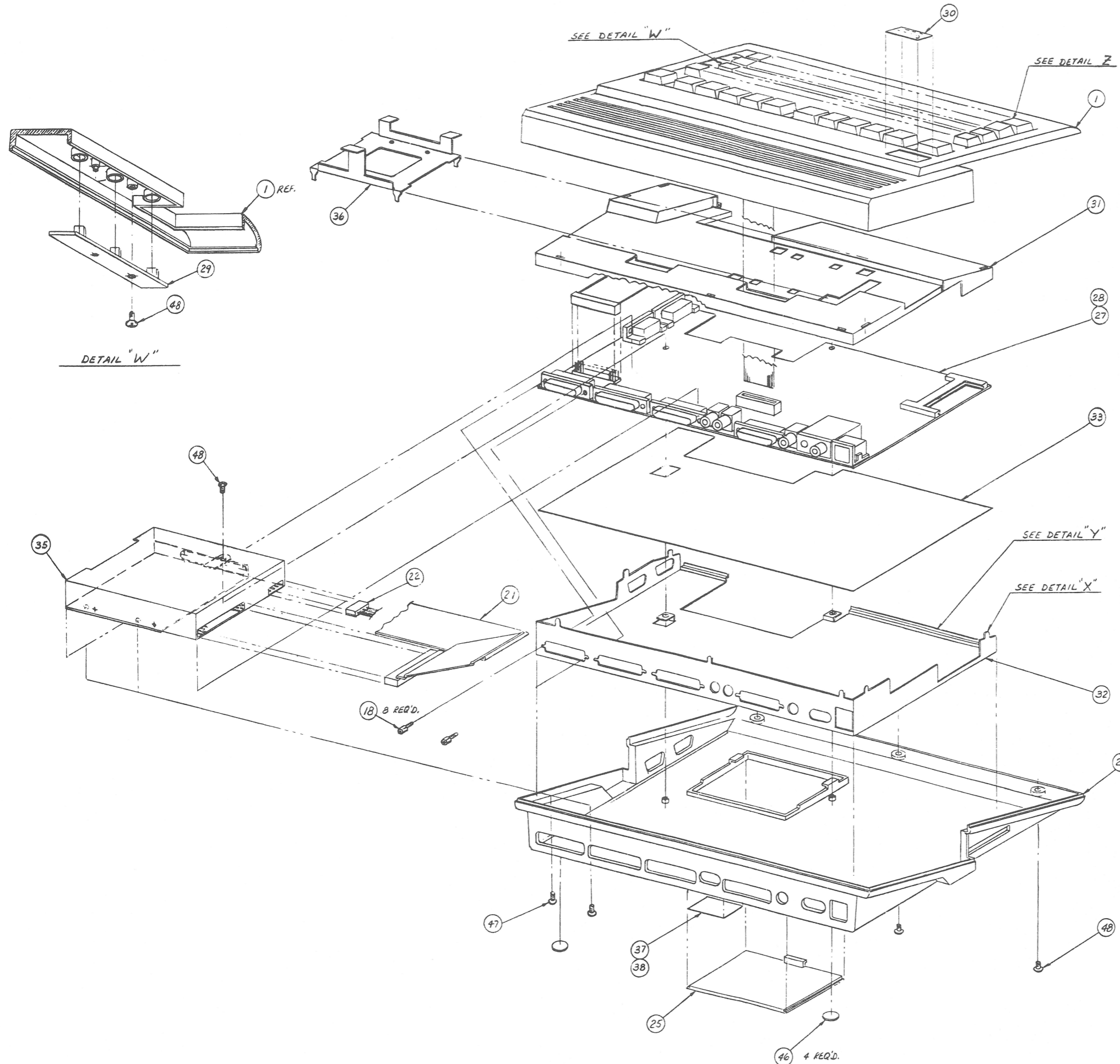

1	TOP CASE	363786-01
18	JACKPOST STANDOFF (QTY 8)	390251-01
21	CABLE ASSY FLOPPY DISK DRIVE	364423-01
22	HARNESS DISK POWER ASSY	327207-02
24	BOTTOM CASE	363787-01
25	RAM DOOR	363899-01
27	PCB ASSY NTSC	315986-01
28	PCB ASSY PAL	315986-02
29	LED ASSY	315992-01
30	NAMEPLATE A600	363951-01
31	TOP SHIELD	363788-01
32	BOTTOM SHIELD	363789-01
33	INSULATION SHEET	363790-01
34	BRACKET SUPPORT FDD	363795-01
35	DRIVE FLOPPY DISK 3.5"	363914-01
36	SUPPORT HARD DISK DRIVE	363969-01
37	LABEL RATING & SERIAL PAL	366800-01
38	LABEL RATING & SERIAL NTSC	366800-02
46	FEET RUBBER WHITE (QTY 4)	950150-01
47	SCREW 3M X 6.0MM MACH PHL PH (QTY 4)	906800-05
	FASTEN FDD TO BOTTOM CASE	

Commodore International Spare Parts List SHIPPING ASSEMBLIES

Commodore part numbers are provided for reference only and do not indicate the availability of spare parts from Commodore. Industry standard parts (Resistors, Capacitors, Connectors) should be secured locally. Part number information may vary according to country, some parts may not be available in all countries. Part Numbers are subject to change.

A600 SHIPPING ASSY		A600 SHIPPING ASSY (Continued)	
530300-01	U.S.	391029-02	POWER SUPPLY BSI 240V
530300-02	CN	391029-03	POWER SUPPLY VDE 220V
530300-03	U.K.	391029-04	POWER SUPPLY SEV 220V
530300-04	GR	391029-05	POWER SUPPLY SAA 220V
530300-05	FR	327124-02	MOUSE ASSY
530300-06	IT	390925-01	CABLE 25 PIN SCART TO 23 PIN D SUB (FOR TV CONN)
530300-07	SP	364346-01	BOX ACCESSORY
530300-08	SG	364342-01	SPACER CARDBOARD
530300-09	SF	364342-02	SPACER CARDBOARD
530300-10	AU NOT USED	318143-02	GLUE WHITE
530300-11	NR	366923-01	LABEL UPC
530300-12	SD	368084-01	SEAL TAMPER EVIDENT (2 ON SINGLE PACK BOX FLAPS)
530300-13	FN	999104-01	TAPE ADHESIVE TRANSPARENT 50MM
530300-14	NE	315938-01	SOFTWARE SUB ASSY U.S.
530300-15	DN	315938-02	SOFTWARE SUB ASSY CN
530300-16	BF	315938-03	SOFTWARE SUB ASSY UK
530300-17	BD	315938-04	SOFTWARE SUB ASSY GR
530300-18	AL	315938-05	SOFTWARE SUB ASSY FR
530300-19	CEL	315938-06	SOFTWARE SUB ASSY IT
530300-20	PG	315938-07	SOFTWARE SUB ASSY SP
364055-01	BOX MASTER SHIPPING	315938-08	SOFTWARE SUB ASSY SG
364056-01	BOX PACK SINGLE	315938-09	SOFTWARE SUB ASSY SF
315995-01	MAIN ASSY US/CN	315938-10	SOFTWARE SUB ASSY NR
315995-02	MAIN ASSY GR/AU	315938-11	SOFTWARE SUB ASSY SD
315995-03	MAIN ASSY FR/BE	315938-12	SOFTWARE SUB ASSY FN
315995-04	MAIN ASSY SD/FN	315938-13	SOFTWARE SUB ASSY NE
315995-05	MAIN ASSY SP	315938-14	SOFTWARE SUB ASSY DN
315995-06	MAIN ASSY DN	315938-15	SOFTWARE SUB ASSY BF
315995-07	MAIN ASSY SEV	315938-16	SOFTWARE SUB ASSY AL
315995-08	MAIN ASSY NR	368435-01	MANUAL INTRODUCING THE A600 ENGLISH
315995-09	MAIN ASSY NE	368436-01	MANUAL INTRODUCING THE A600 GERMAN
315995-10	MAIN ASSY UK/AL	368437-01	MANUAL INTRODUCING THE A600 FRENCH
315995-11	MAIN ASSY IT	368438-01	MANUAL INTRODUCING THE A600 ITALIAN
315995-12	MAIN ASSY PG	368439-01	MANUAL INTRODUCING THE A600 SPANISH
1540025-01	BAG POLY ANTISTATIC	368440-01	MANUAL INTRODUCING THE A600 NORWEGIAN
324457-01	BAG DRYING AGENT	368441-01	MANUAL INTRODUCING THE A600 SWEDISH
364057-01	ENDCAP LEFT	368443-01	MANUAL INTRODUCING THE A600 DUTCH
364057-02	ENDCAP RIGHT	368444-01	MANUAL INTRODUCING THE A600 DANISH
391029-01	POWER SUPPLY UL/CSA 110V		

Commodore International Spare Parts List A600 MAJOR ASSEMBLIES

Commodore part numbers are provided for reference only and do not indicate the availability of spare parts from Commodore. Industry standard parts (Resistors, Capacitors, Connectors) should be secured locally. Part number information may vary according to country, some parts may not be available in all countries.

315995-01	MAIN ASSY US/CN	315986-02	PCB ASSY PAL
315995-02	MAIN ASSY GR/AU	315986-03	PCB NTSC 1M
315995-03	MAIN ASSY FR/BE	315992-01	LED ASSY
315995-04	MAIN ASSY SD/FN	363951-01	NAMEPLATE A600
315995-05	MAIN ASSY SP	363788-01	TOP SHIELD
315995-06	MAIN ASSY DN	363789-01	BOTTOM SHIELD
315995-07	MAIN ASSY SEV	363790-01	INSULATION SHEET
315995-08	MAIN ASSY NR	363795-01	BRACKET SUPPORT FDD
315995-09	MAIN ASSY NE	363914-01	DRIVE FLOPPY DISK 3.5"
315995-10	MAIN ASSY UK/AL	363969-01	SUPPORT HARD DISK DRIVE
315995-11	MAIN ASSY IT	366800-01	LABEL RATING & SERIAL PAL
315995-12	MAIN ASSY PG	366800-02	LABEL RATING & SERIAL NTSC
363786-01	TOP CASE	366800-03	LABEL RATING & SERIAL PAL (SUBSTITUTE)
363756-01	KEYBOARD ASSY US/CN	366800-04	LABEL RATING & SERIAL NTSC (SUB)
363756-04	KEYBOARD ASSY GERMAN	366800-05	LABEL RATING & SERIAL PAL (SUB)
363756-05	KEYBOARD ASSY FRENCH	366800-06	LABEL RATING & SERIAL NTSC (SUB)
363756-12	KEYBOARD ASSY SWEDISH/FINNISH	366800-07	LABEL RATING & SERIAL PAL (SUB)
363756-07	KEYBOARD ASSY FINNISH	366800-08	LABEL RATING & SERIAL NTSC (SUB)
363756-15	KEYBOARD ASSY DANISH	950150-01	FEET RUBBER WHITE (QTY 4)
363756-08	KEYBOARD ASSY SWISS	906800-05	SCREW 3M X 6.0MM MACH PHL PH (QTY 4) FASTEN FDD TO BOTTOM CASE
363756-11	KEYBOARD ASSY NORWEGIAN	906883-01	SCREW 3M X 6.0MM SELF TAPPING (QTY 4) FASTEN PCB, FDD BKT TO BOTTOM CASE
363756-03	KEYBOARD ASSY UK/AUSTRALIA	364075-01	SCHEMATIC
363756-06	KEYBOARD ASSY ITALIAN	391033-02	LED GREEN
363756-20	KEYBOARD ASSY PORTUGUESE	391033-01	LED YELLOW
363756-99	KEYBOARD ASSY BLANK	391315-01	CONNECTOR HOUSING 4 POSITION
390251-01	JACKPOST STANDOFF (QTY 8)	391316-01	PIN
390251-03	JACKPOST STANDOFF (SUB FOR 390251-01)	903756-10	WIRE AWG #24 BLACK 200MM LG.
324530-02	JACKPOST STANDOFF (SUB FOR 390251-01)	903756-02	WIRE AWG #24 RED 200MM LG.
363787-01	BOTTOM CASE	903756-03	WIRE AWG #24 ORANGE 200MM LG.
363899-01	RAM DOOR	903756-05	WIRE AWG #24 GREEN 200MM LG.
364423-01	CABLE ASSY FLOPPY DISK DRIVE		
327207-02	HARNESS DISK POWER ASSY		
315986-01	PCB ASSY NTSC		

A601 RAM EXPANSION

580300-01	512K	580300-02	1M
-----------	------	-----------	----

HARD DRIVE ACCESSORIES

368681-01	INTRO MANUAL	906600-01	SCREW (QTY 4)
368712-01	MANUAL USERS	367826-01	DISK INSTALL 204
312896-01	HDD ASSY	363951-02	NAMEPLATE A600HD
364435-01	CABLE HDD		

Commodore International Spare Parts List

PCB Components

PCB Assembly A600

Commodore part numbers are provided for reference only and do not indicate the availability of spare parts from Commodore. Industry standard parts (Resistors, Capacitors, Connectors) should be secured locally. Part number information may vary according to country, some parts may not be available in all countries.

IC COMPONENTS			RESISTORS — 1/8W 5% UNLESS OTHERWISE SPECIFIED (Continued)		
390084-01	CPU MC68000FN8 8MHZ 68PIN PLCC	U1	310026-12	SM 68 OHM (1206)	E131R,E132R,E251R, E252R,E257R,E261R, E262R,E266R,E267R, E351R,E353R-E358R, E361R,E363R-E368R, E371R-E374R,E511R- E523R,E525R,E551R- E556R,E558R,E581R- E596R,E692R-E694R, R151A-R151H,R152A R232E,R234A-R234D R237,R622,R639 R236,R714A,R714B R211-R213,R233A-R233C R214A,R215A,R216A R214F,R215F,R216F R235,R321,R331 R325,R335 R111,R161,R162,R515, R659,R660,R952,R953A- R953C R224 R101,R102,R222,R223, R303,R304,R319,R324, R334,R511D,R103,R512, R621,R654,R954A, R954B,R231A-R231C, R238,R214B,R215B, R216B (R244) R221 R214C,R215C,R216C R347,R571 R251-R253,R348,R632, R634,R636,R655,R951A- 951F,R370A-370H,R651, R719,R514,R715X (R241) R322,R323,R327,R329, R332,R333,R337,R339, R346,R511A-R511C, R511F,RR511I,R637, R572,R623,R631,R633, R635,R652,R653,R656, R657,R715A-R715H, R716-R718 (R243) R345 R459 R232A-R232C,R349 R612 R326,R336 R611 R301,R302 (R242 FOR PAL) (R245 FOR PAL) R246 NTSC (R236 FOR PAL) R214D,R215D,R216D R214E,R215E,R216E R214B,R215B,R216B R214C,R215C,R216C R309,R405A,R405B E232R,R352,R362,R406 E524R
390544-02	8375R0 AGNUS HR NTSC 84 PIN PLCC	U2	310026-29	SM 75 OHM (1206)	
390544-01	8375R0 AGNUS HR PAL 84PIN PLCC	U2	310026-05	SM 100 OHM (1206)	
391155-01	4145R0FO20 GAYLE 84PIN PLCC	U5	310026-24	SM 120 OHM (1206)	
391081-01	8375R4 DENISE HR 52PIN PLCC	U4	310026-13	SM 150 OHM (1206)	
391077-01	8364R7 PAULA 52PIN PLCC	U3	310026-40	SM 270 OHM (1206)	
391079-01	6571R4 KEYBD UP 44PIN PLCC	U13	310022-22	SM 330 OHM (1206)	
391078-01	8520R4 CIA 44PIN PLCC 1MHZ	U7,U8	310026-14	SM 360 OHM (1206)	
391144-01	74HCT244 SM	U31,U32	310026-15	SM 390 OHM (1206)	
391139-01	74FOO SM	U26	310026-21	SM 470 OHM (1206)	
391140-01	74F27 SM	U36	310026-11	SM 820 OHM (1206)	
391141-01	74LS74A SM PAL	U33	310026-07	SM 1K OHM (1206)	
391218-01	74F02 SM	U44			
391142-01	74LS245 SM	U21,U22,U41-U43,U45- U47			
391085-01	74LS157 SM	U34			
391176-01	74F139 SM	U27			
391099-01	74F258 SM	U25			
390071-03	PAL 16L8B BLANK (WILL BE USED ONLY TEMPORARILY W/REV 0 GAYLE)				
391087-01	INTERFACE MC1488D SM	U28			
391086-01	INTERFACE MC1489D SM	U29			
391103-01	LINEAR LF347/TL084ACD SM	U15			
391104-01	LINEAR NE555 SM	U14			
391105-01	DRAM 256K X 16 80NS SM	U16,U17			
391304-01	ROM KICKSTART V2.0 40PIN DIP	U6			
391084-01	VIDEO ENCODER CXA1145M SM	U12			
CONNECTORS					
390241-03	D SUB 23 PIN FEMALE DB23S	CN5 EXTERNAL FLOPPY	310026-25	SM 1.5K (1206)	
390242-03	D SUB 23 PIN MALE DB23P	CN9 RGB VIDEO	310026-32	SM 2K OHM (1206)	
390241-05	D SUB 25 PIN FEMALE DB25S	CN7 PARALLEL PRINTER PORT	310026-16	SM 2.7K OHM (1206)	
390242-01	D SUB 9 PIN MALE DB9P	CN1,CN2,MOUSE/JOY- STICK	310026-08	SM 4.7K OHM (1206)	
252122-01	RCA JACK YELLOW	CN10,COLOR COM- POSITE VIDEO			
252122-01	RCA JACK WHITE	CN4 LEFT AUDIO	310026-17	SM 10K OHM (1206)	
252122-02	RCA JACK BLACK	CN3 RIGHT AUDIO			
252167-01	DIN 5 PIN SQUARE	CN8 CPU POWER			
325516-04	SIL 4PIN HEADER	CN12,FLOPPY POWER/LED			
903345-17	DIL 34PIN HEADER W/KEY (PIN3)	CN11 FLOPPY SIGNAL			
391153-01	DIL 44PIN HEADER W/KEY (PIN20)	CN16 HDD			
391073-01	68 PIN RIGHT ANGLE HIGH DENSITY	CN15 CREDIT CARD			
390492-02	30 PIN LOCKING ZIF FFC	CN13 KEYBOARD			
391314-01	HEADER RT ANGLE 4 PIN POLARIZED	CN14 LED			
TRANSISTORS AND DIODES					
391145-01	TRANS JFET MPF102/PN4302 SOT23	Q321,Q331	310026-23	SM 22K OHM (1206)	
391121-01	TRANS NPN 2N3904 SOT23	Q211-Q213,Q231-Q233, Q511,Q571,Q621,Q622, Q651,Q653,(Q461 PAL)	310026-27	SM 27K OHM (1206)	
391122-01	TRANS PNP 2N3906 SOT23	Q341,Q631-Q633,Q652, Q654	310026-18	SM 33K OHM (1206)	
391129-01	DIODE 1N4148 SOT23	D571	310026-03	SM 47K OHM (1206)	
391128-01	DIODE 1N914 SOT23 (SUB FOR 391129-01)	D571	310026-19	SM 470K OHM (1206)	
391327-01	DIODE 1N4001 MELF	D572-D576	310026-20	SM 1M OHM (1206)	
RESISTORS — 1/8W 5% UNLESS OTHERWISE SPECIFIED					
310026-26	SM 0 OHM (1206) NTSC JUMPERS	E321R,E331R,R202, R225,(R624-R626 NOT STUFFED)	310026-09	SM 10 OHM (1206)	
310026-26	SM 0 OHM (1206) PAL JUMPERS	E321R,E331R,R203 (R624-R626 NOT STUFFED)	310026-35	SM 6.8K OHM (1206)	
310026-10	SM 27 OHM (1206)	R113,R114,R152B- R152H,E112R,E120R- E129R,E150R	310026-41	CHIP SM 1.8K (1206)	
310026-01	SM 47 OHM (1206)	E253R-E256R,E577R, E561R,E562R,E524R			
			CAPACITORS		
			390818-03	SM NPO 15PF (1206)	(C242 PAL)
			390818-04	SM NPO 47PF (1206)	E258C-E260C,E-692C, E693C,E150C,E151E-E154, E694C
			390818-05	SM NPO 56PF (1206)	C245, (C241 PAL)

Commodore International Spare Parts List
PCB Components (Continued)
PCB Assembly A600

CAPACITORS (Continued)		CAPACITORS (Continued)	
390818-06	SM NPO 100PF (1206)	E231C,E251C-E257C, E261C,E262C,E266C, E267C,E511C-E523BC, E525C,E551C,E552C, E558C,E581C-E596C	390818-01 SM NPO 22PF (1206)
390853-06	SM X7R 470PF (1206)	E351C,E353C,E354C, E361C,E363C,E364C, E371C-E374C,E553C- E556C (C243 PAL) C323,C333	391097-07 ALUM ELECT 10UF 25V SM (C) 391097-08 ALUM ELECT 22UF 25V SM (D)
390853-07	SM X7R 1000PF (1206)	E321C,E331C,C322,C332, E355C-E358C,E365C- E368C	391097-04 ALUM ELECT 47UF 16V SM (D) 391097-01 ALUM ELECT 100UF .63V SM (D) 390101-10 ALUM ELECT 1000UF 10V 390101-03 ALUM ELECT 470UF 16V
390853-08	SM X7R 3900PF (1206)	C246,C26,C27,C28A, C28B,C29,C33,C34,C36, C349,E597C,E598C,C591, C613,C800-C803,E232C, E263C-E265C,E524C, E557C,E561C,E562C, C592,C7,C8, (C244 PAL) C311-C314,C352	MISCELLANEOUS
390853-09	SM X7R 6800PF (1206)	C221,C222,C362,C611, (C321,C331,NOT STUFFED)	391092-01 FILTER CHIP FERRITE BEAD LARGE (1812) 391092-01 FILTER CHIP FERRITE BEAD MEDIUM (1206)
390853-01	SM X7R .01UF (1206)	C12A,C12B,C13,C14, C16A,C16B,C17A,C17B, C1A,C1B,C2-C4,C21, C211-C213,C22,C25, C301,C302,C305,C31, C41-C43,C32,C551,C552, C5A,C5B,C6,C701,C702, C711,C804,C199,C44- C47	E301,FB991-FB993 E231R,E258R-E260R, E263R-E265R,E597R, E598R LF 1 Z221 Z222 Z221 Z222 (L241) Y621 (Y451) X1 (X1) U6 X2 (X2)
390853-04	SM X7R .047UF (1206)		251878-02 LINE FILTER 391146-02 BANDPASS FILTER NTSC (F-K5-MS) 391147-02 DELAY LINE NTSC (F K5 MD) 391146-01 BANDPASS FILTER PAL (BPF K5 MS) 391147-01 DELAY LINE PAL (F KS MT) 391138-01 INDUCTOR SM 1.2UH (1206) 391156-01 RESONATOR CERAMIC 3.00 MHZ 252345-01 XTAL 4.433619 MHZ 325566-14 OSCILLATOR 28.63636 MHZ NTSC 252344-01 OSCILLATOR 28.37516 MHZ PAL 904150-09 SOCKET 42 PIN DIP 313371-01 MODULATOR MDG VA3424 NTSC 313371-05 MODULATOR MDG UD 3626 PAL 366648-01 LABEL BAR CODE BLANK 0.5" X 1.75" 366649-01 LABEL BAR CODE BLANK 0.5" X 1.00"
310027-02	SM Z5U .1UF (1206)		
390797-01	SM Z5U .33UF (1210)		

SECTION 5
SCHEMATICS

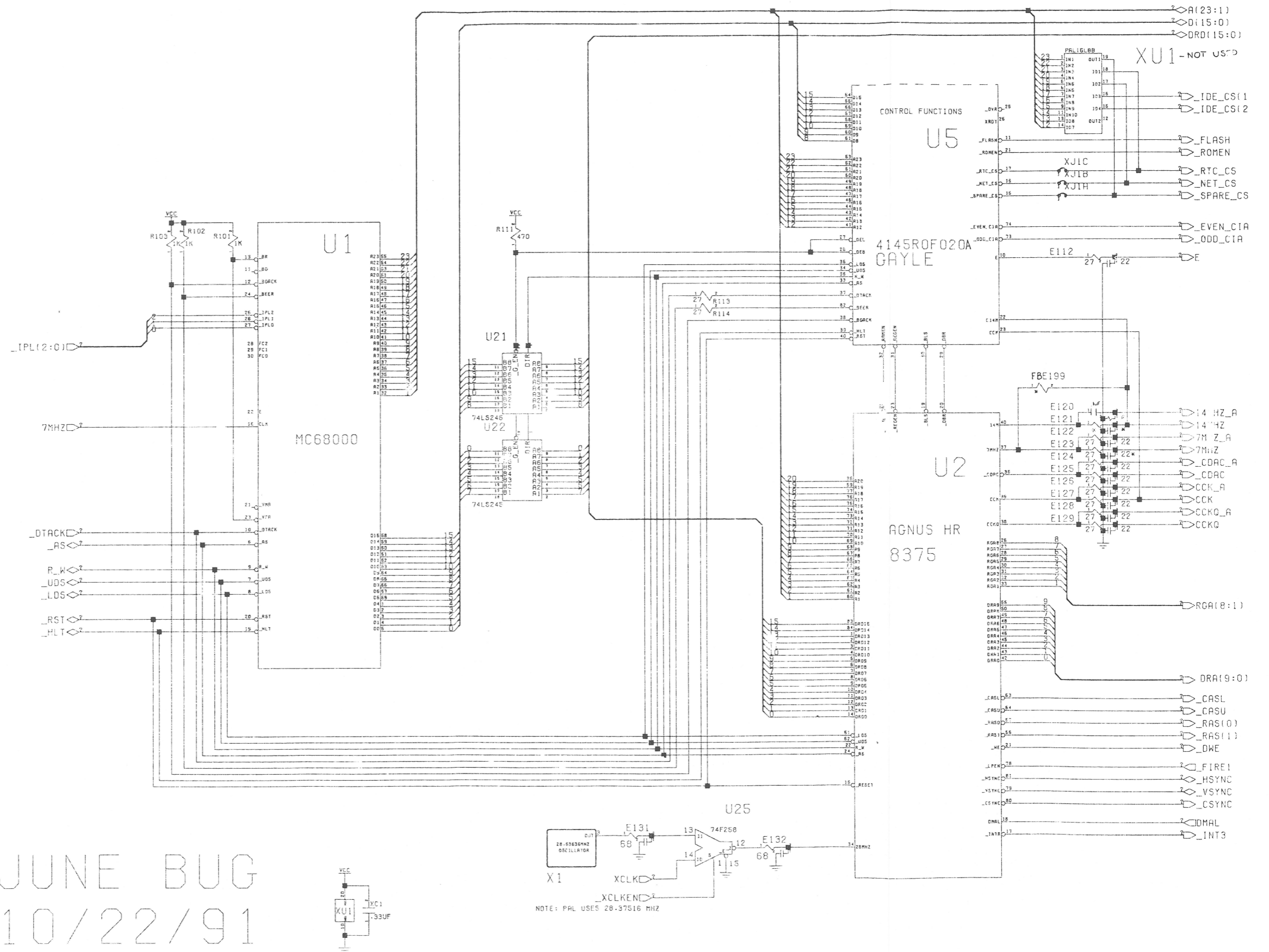

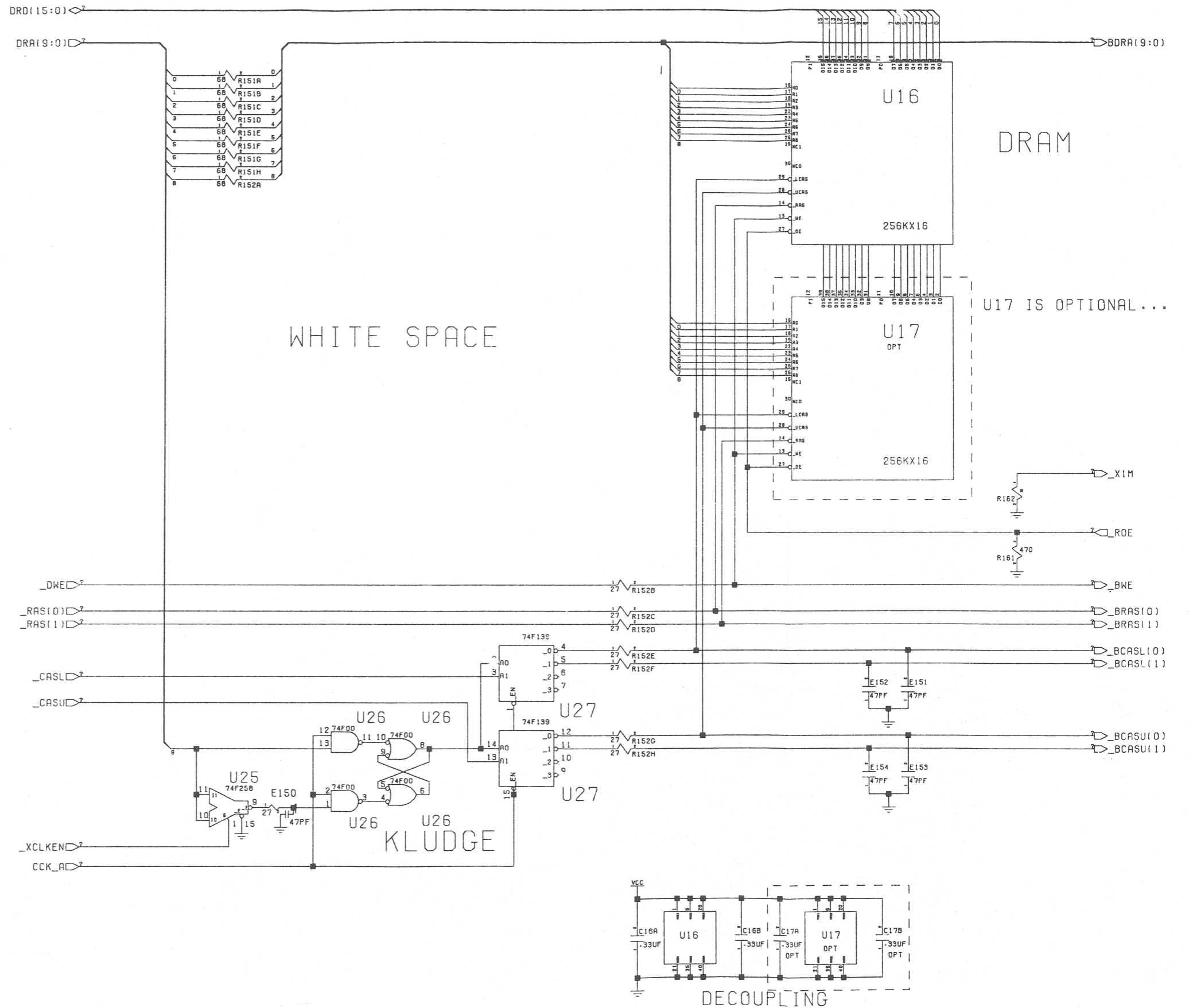

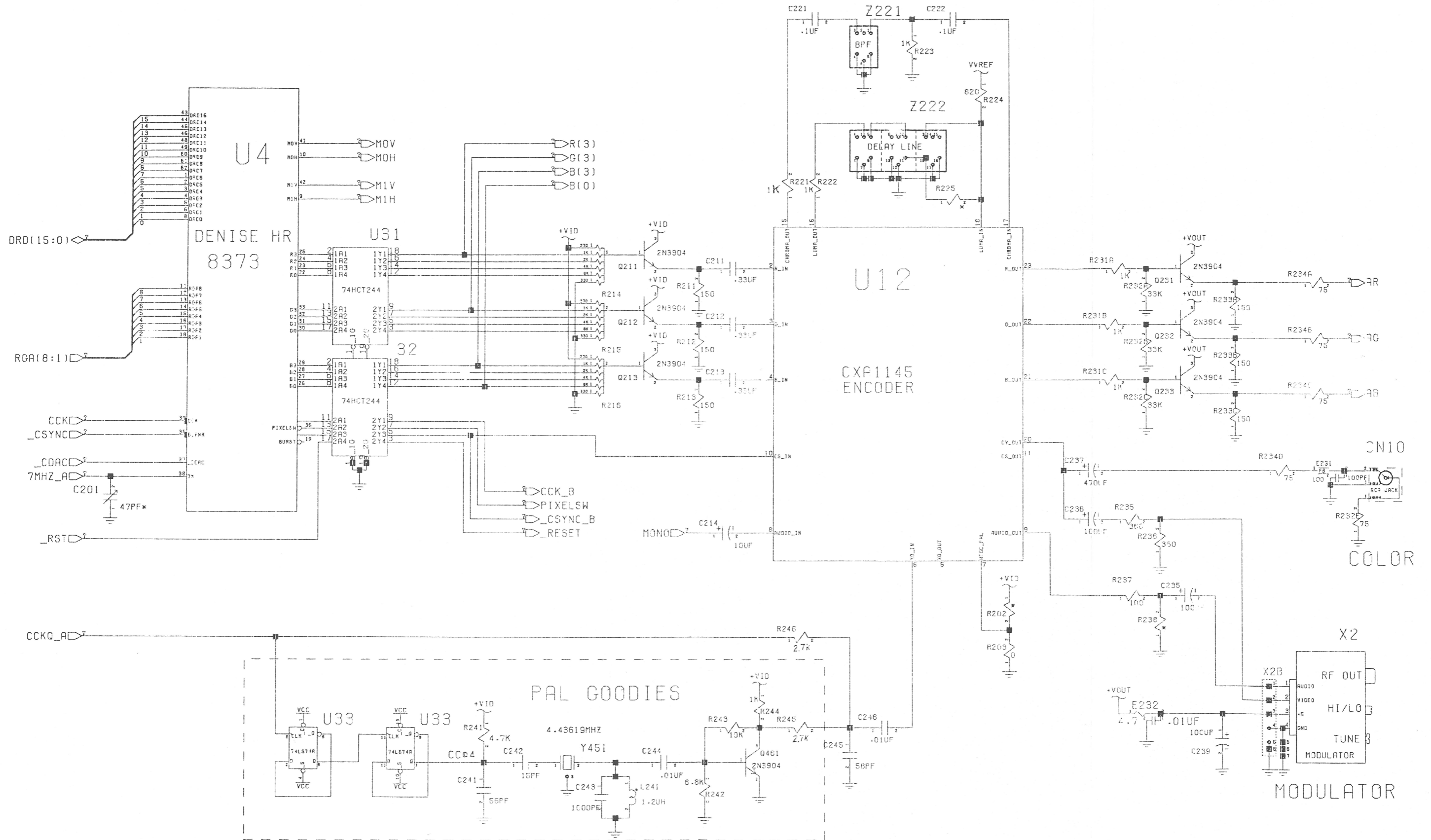

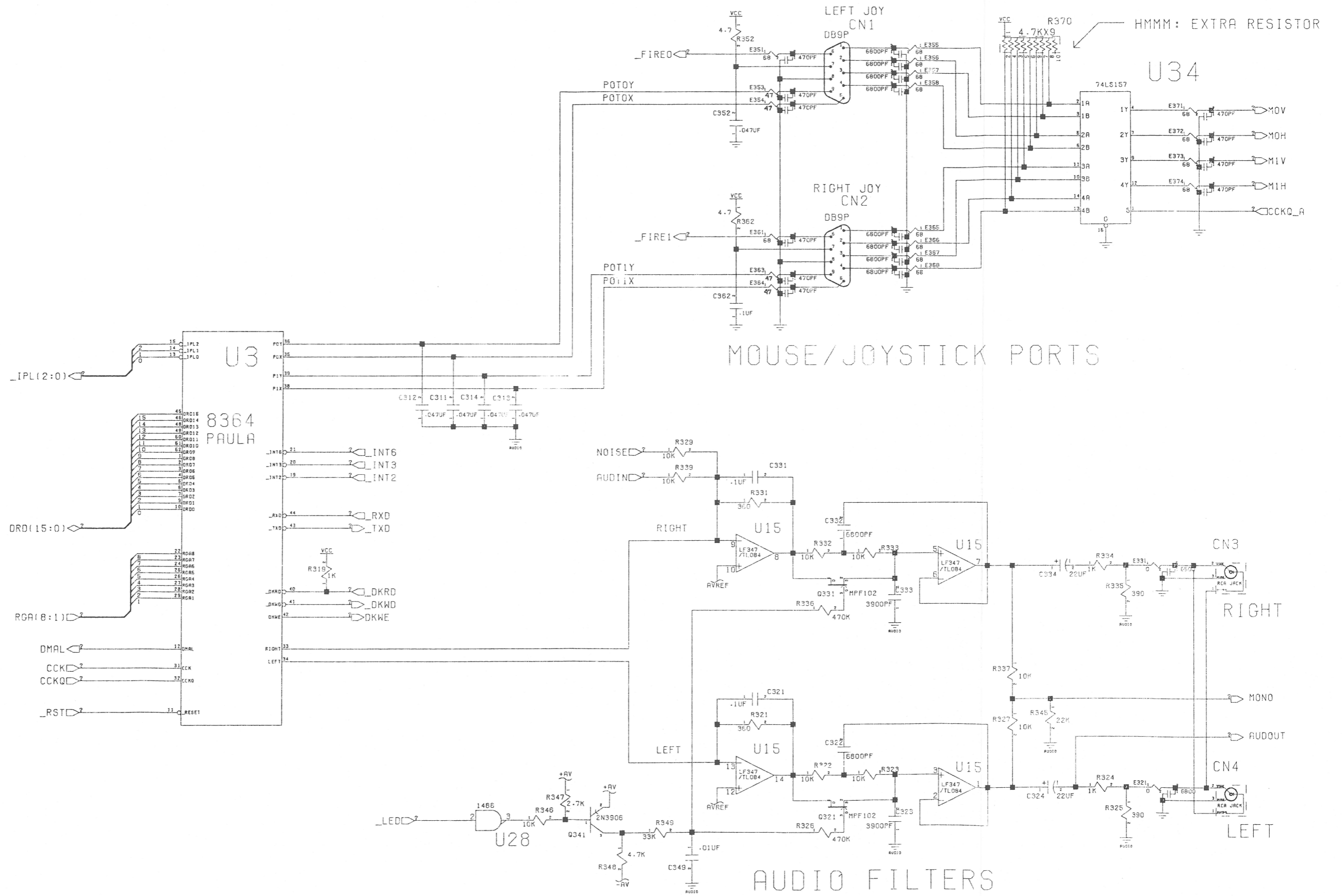

NOTE: LED OFF. FILTERS BYPASSED

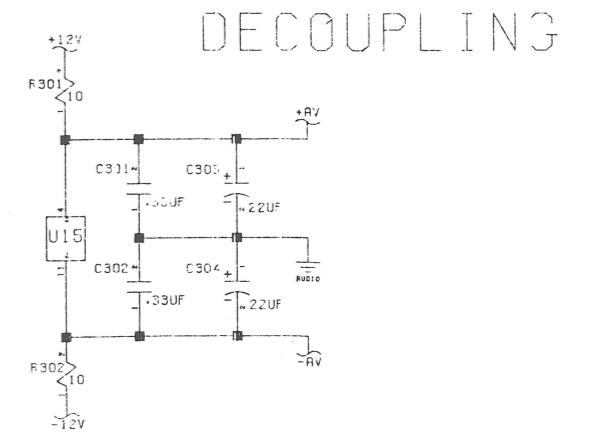
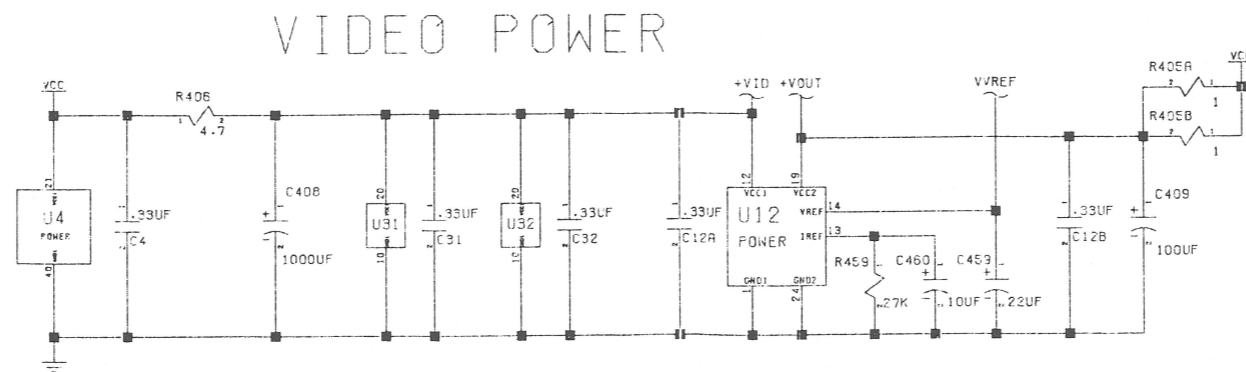
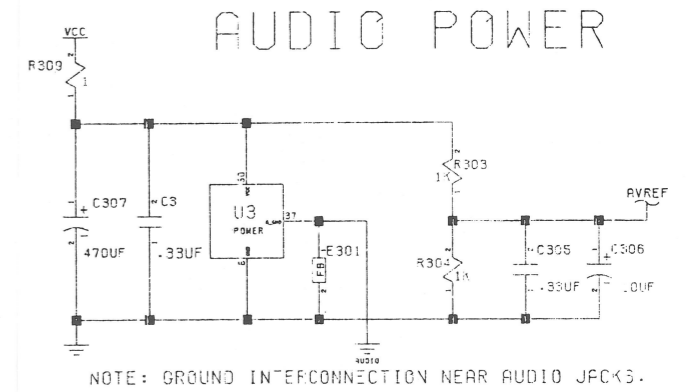
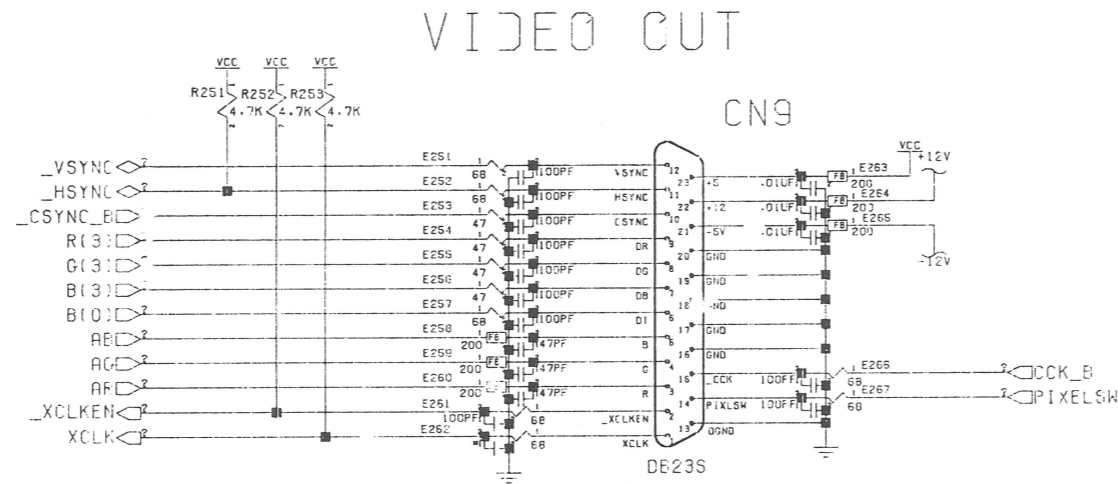
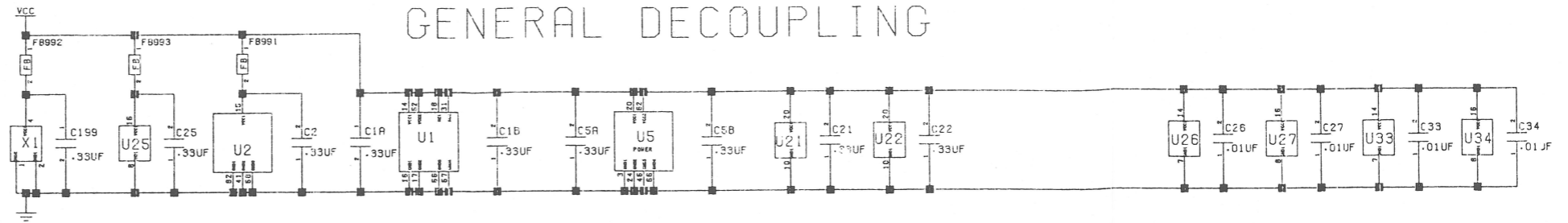

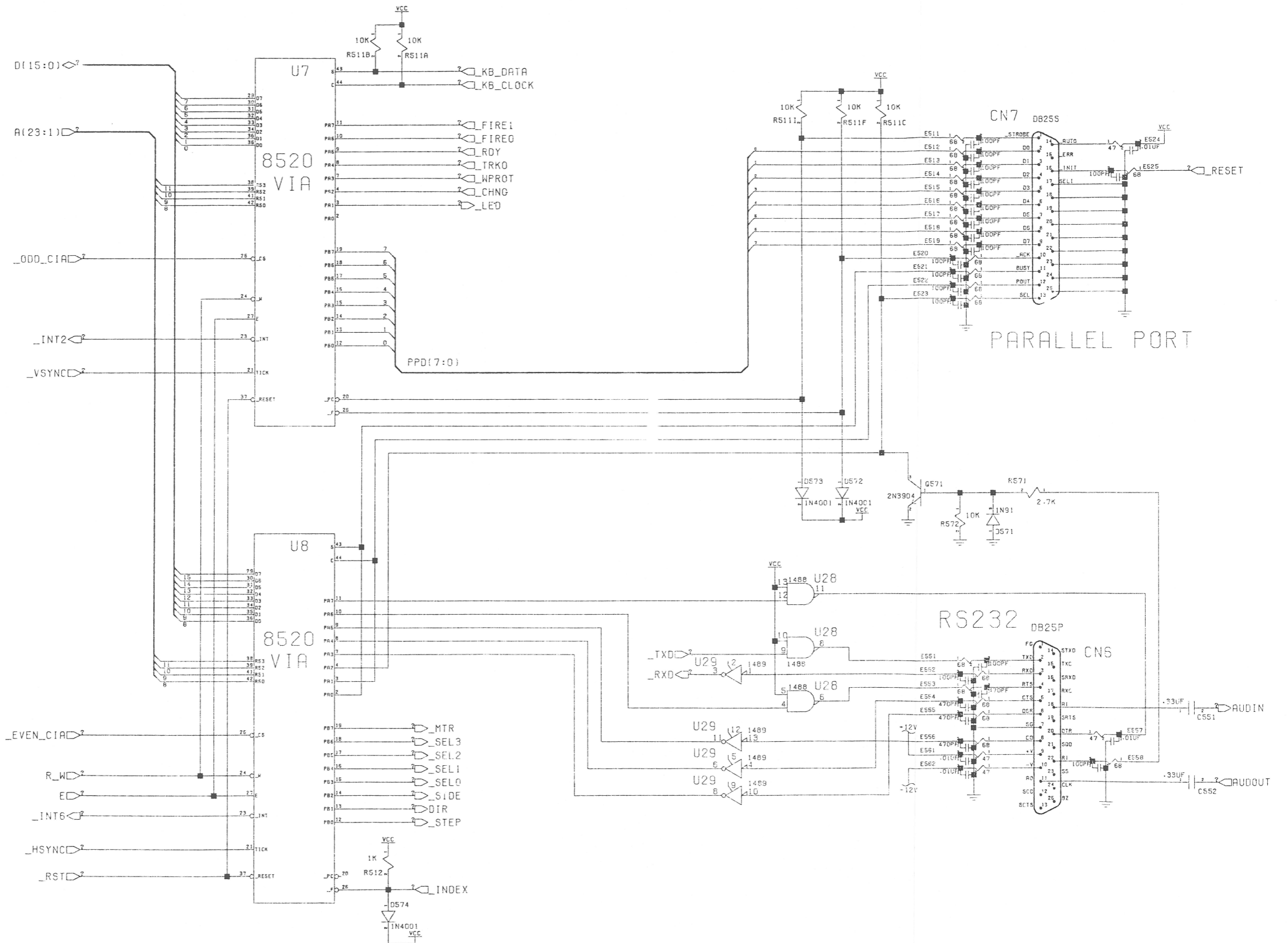

FLOPPY LOGIC

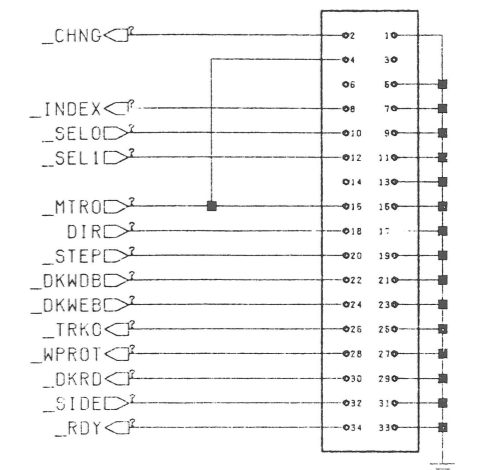
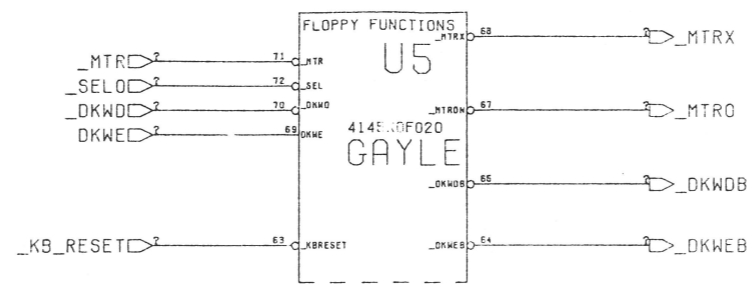

FLOPPY POWER

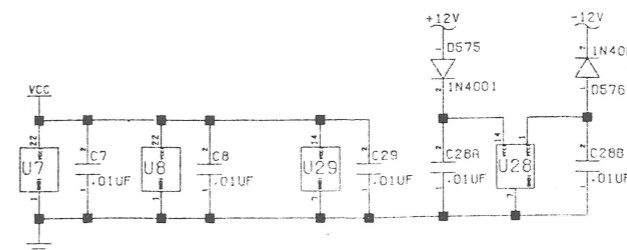
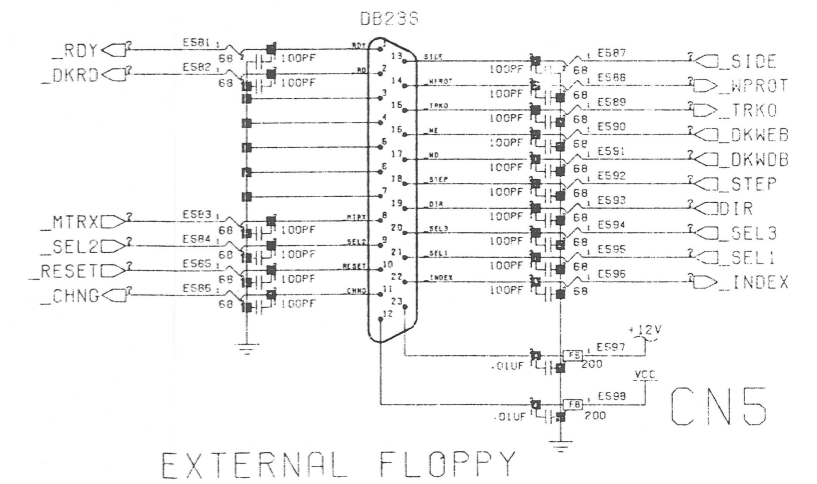
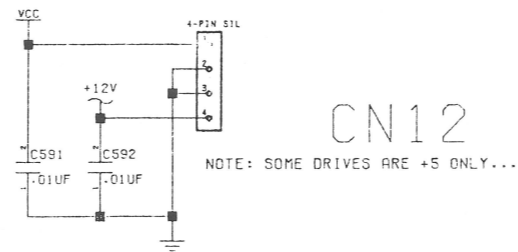

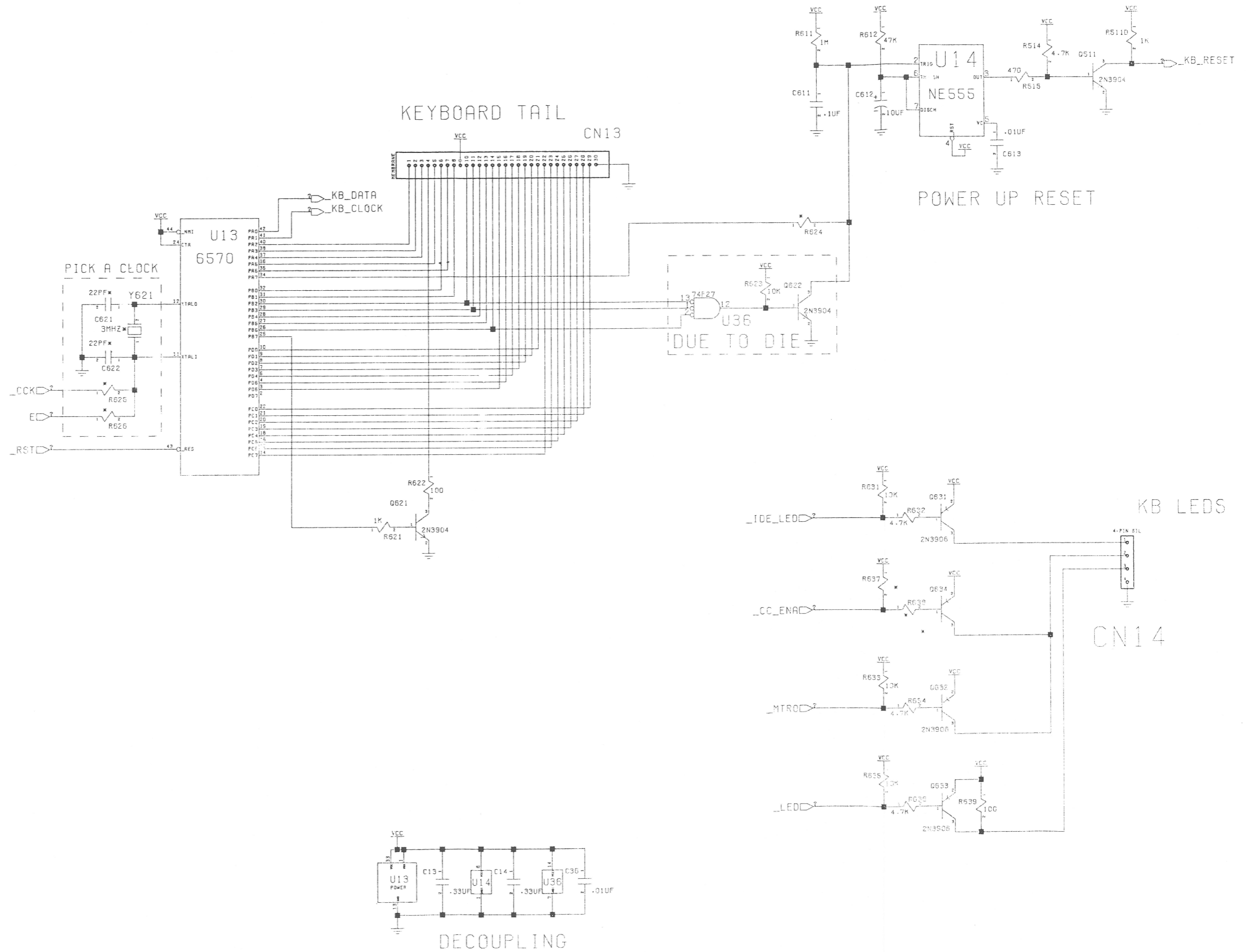

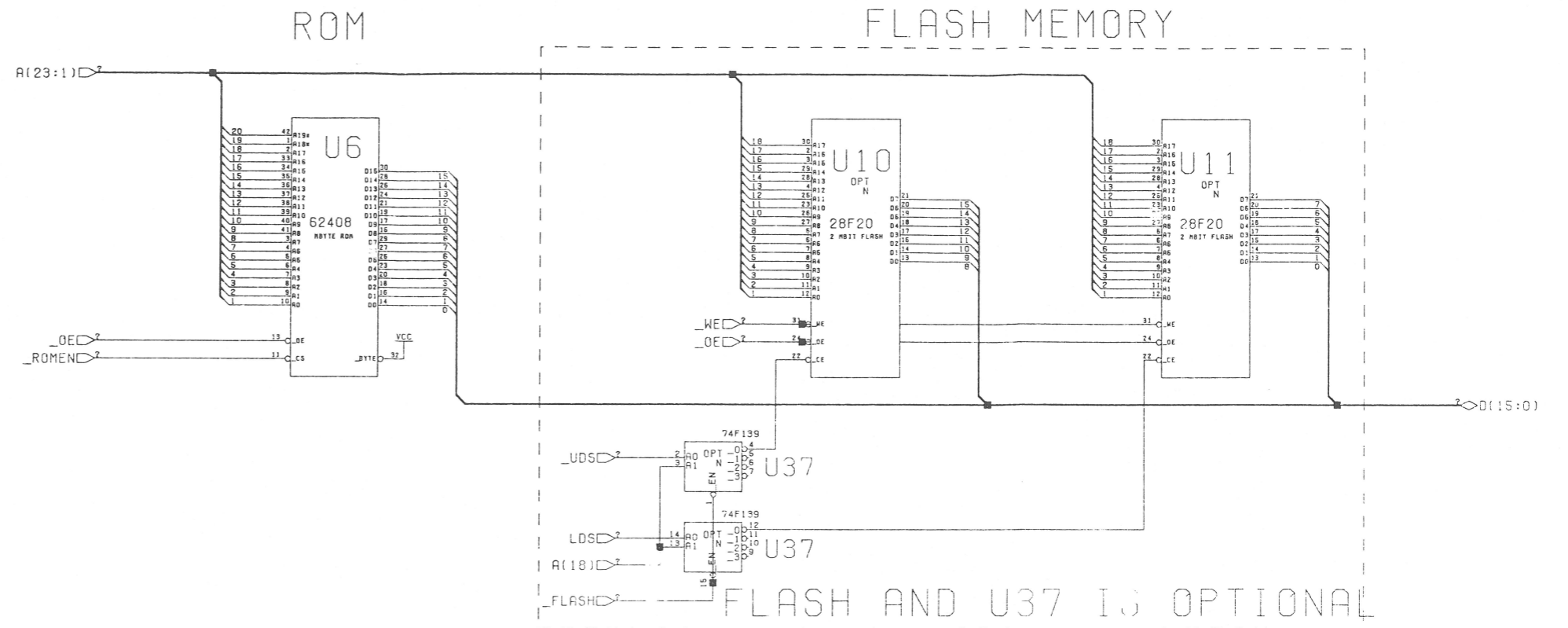

PROGRAMMING VOLTAGE

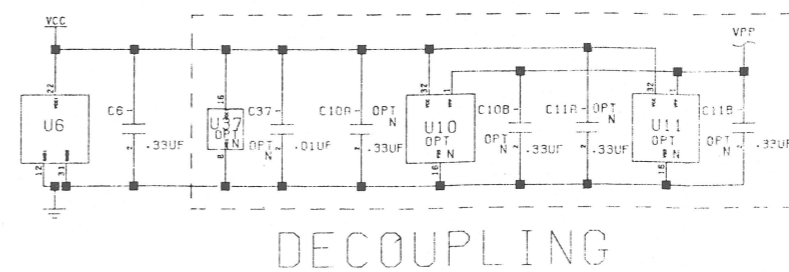
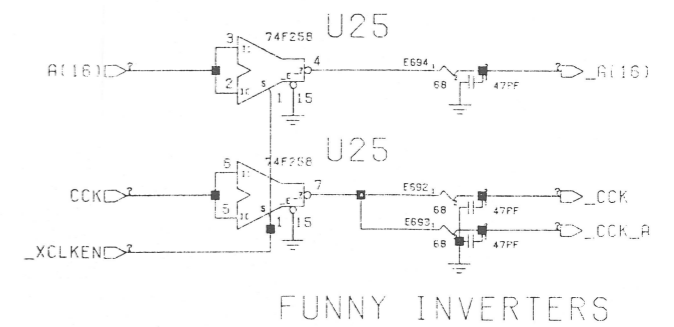
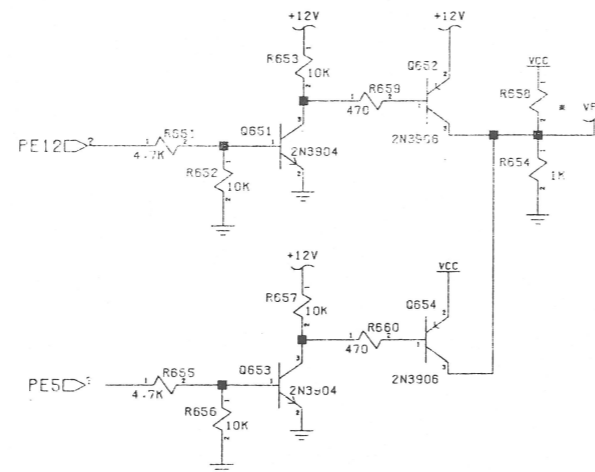

MEMORY CARD

CN15

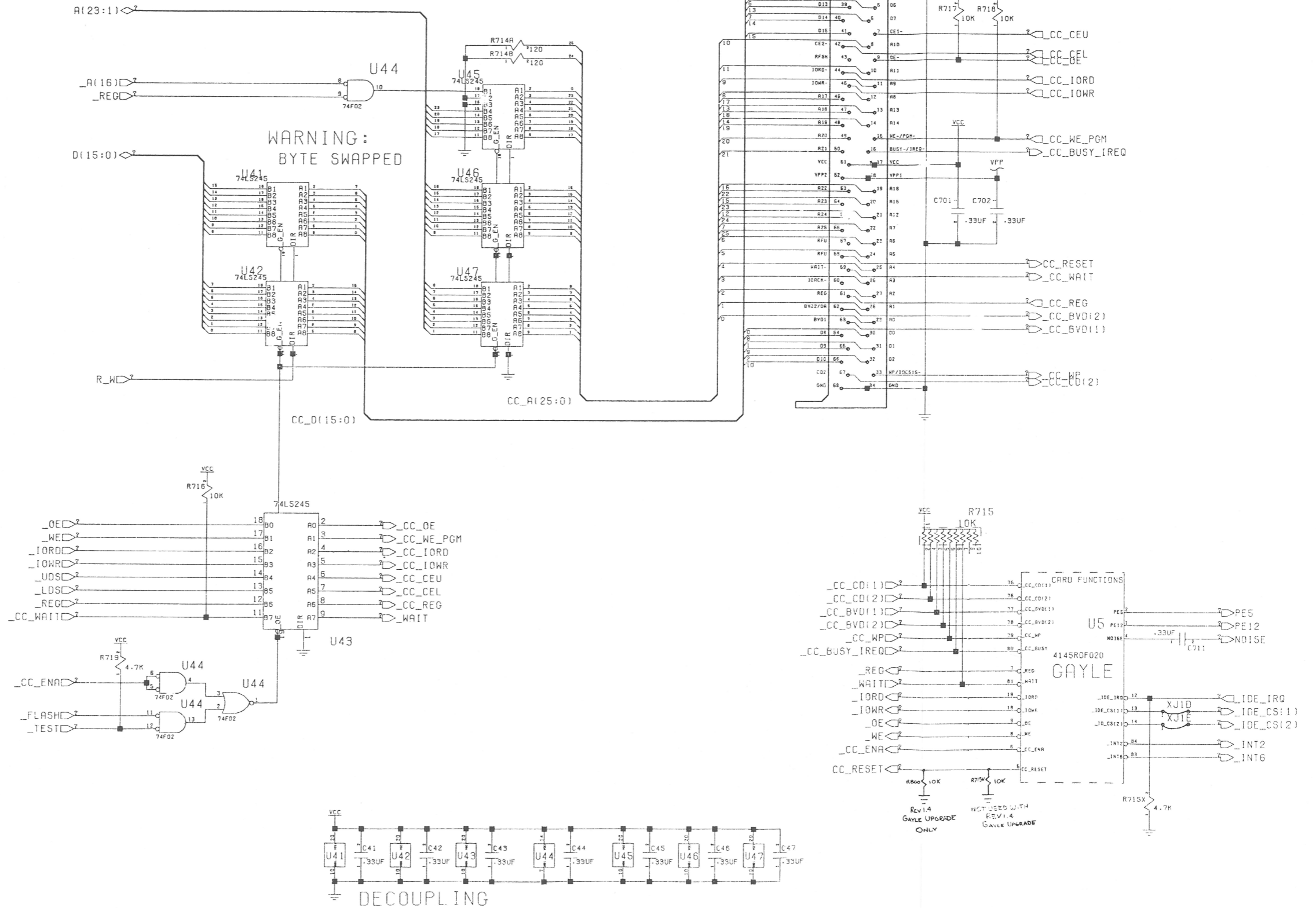

MEMORY EXPANSION

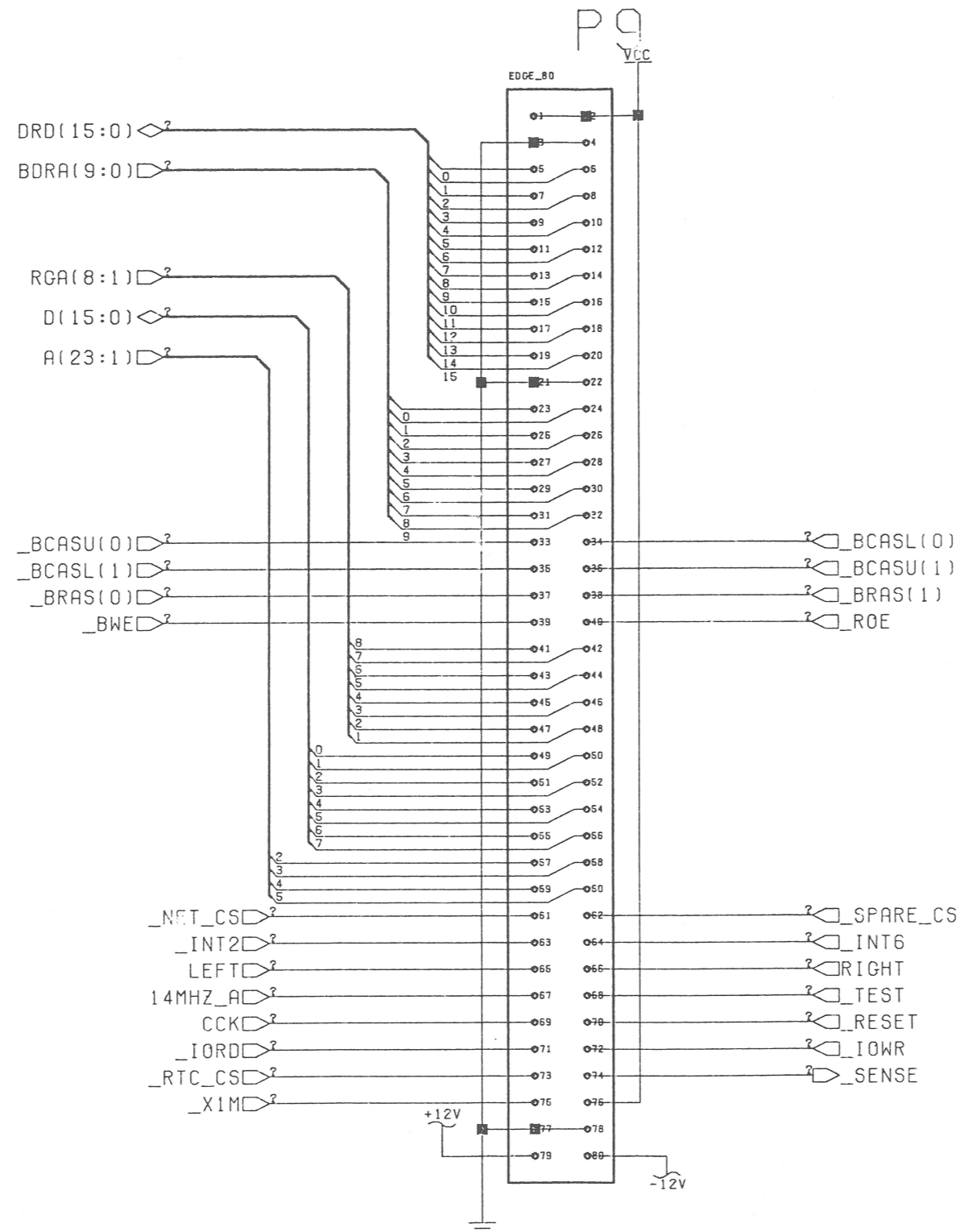

IDE DRIVE

CN16

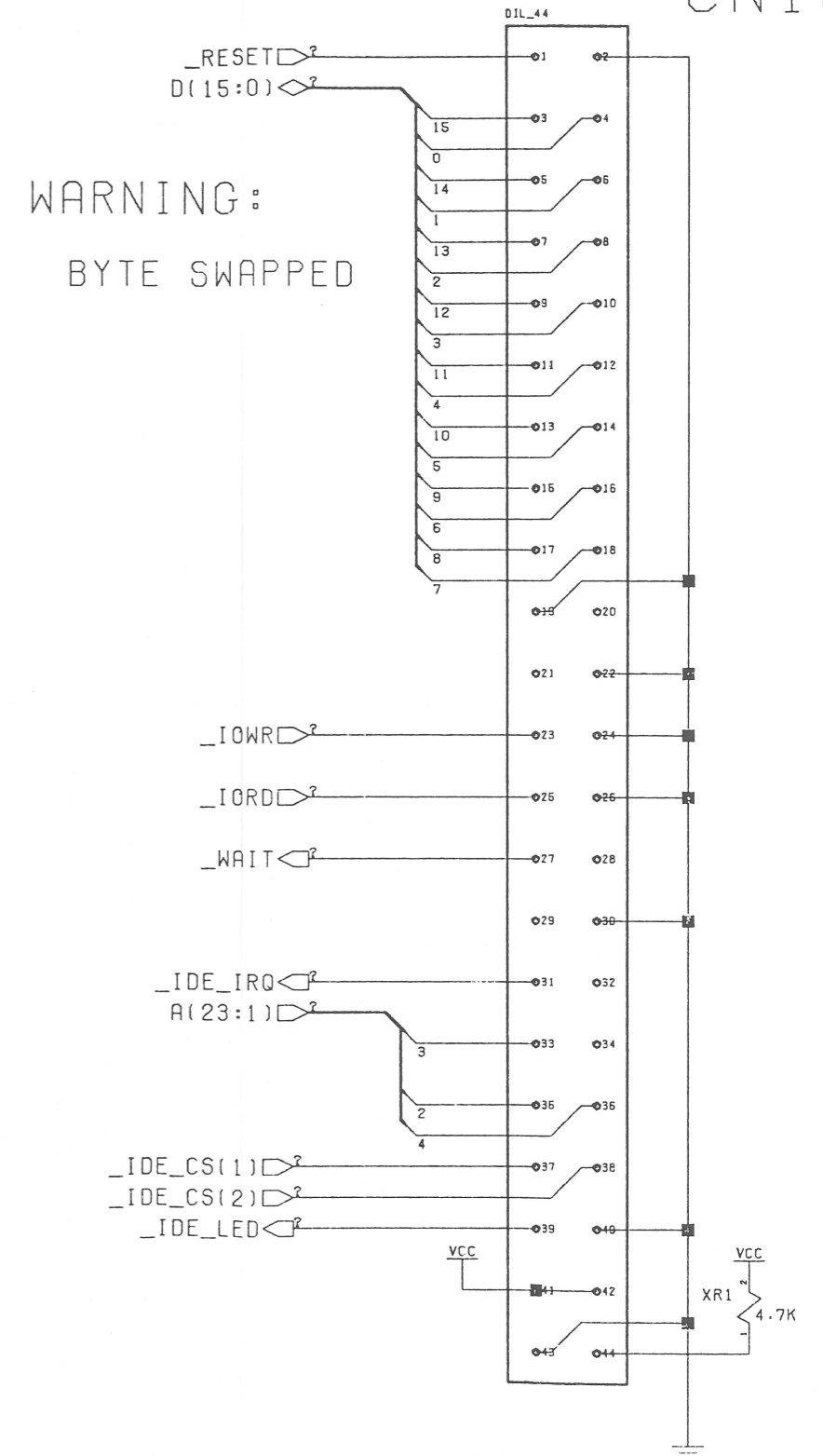

POWER INPUT

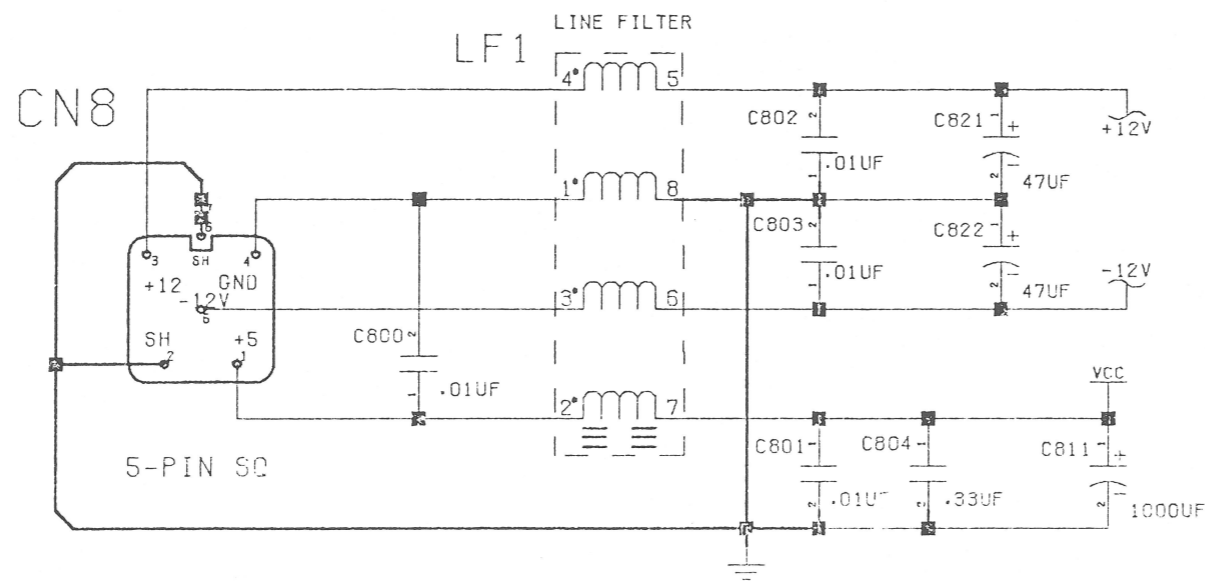

NOTE: HEAVY LINES INDICATE A SINGLE POINT CONNECTION

GROUNDING HOLES, &C.

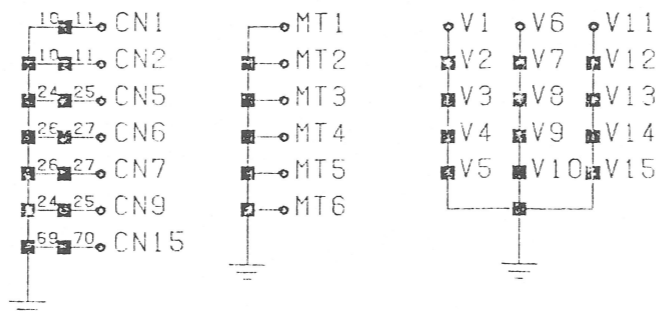

"BUS" TERMINATION

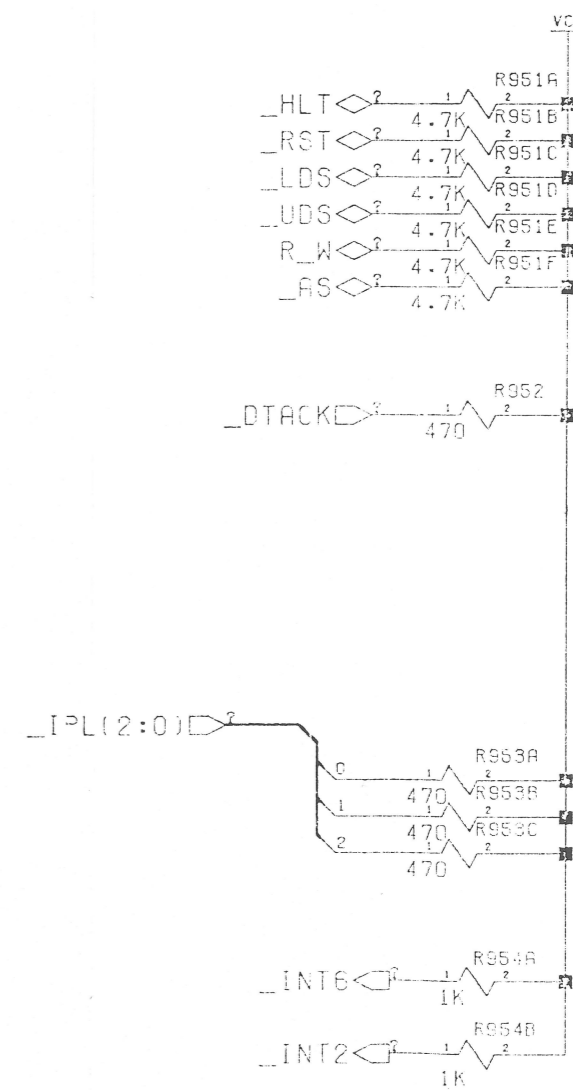



Technical Training
Friedrich-Seele-Straße 10
3300 Braunschweig

Tel.: (05 31) 89 50 63 · Fax: (05 31) 8 57 74